

# Rohinson

## SmartChef<sup>XL</sup> 2

### Wi-Fi Soft Cooking Air Fryer





Instruction Manual

Model: R-2858



Please read this manual carefully before using the device.

## Connect your device to the Rohnson app

1. Install the Rohnson app on your smartphone via Android or IOS.
2. Create an account. For more information, see the "Login Details" section.
3. Pair the Air Fryer with the Rohnson app on your smartphone. When the device is first turned on, it may automatically enter pairing mode that the WIFI signal lighting  is slowly flashing (flash every 2 seconds). If the WIFI signal lighting  is off, then you need to long press the WIFI icon , you will hear 3 beep sounds. Here, it means air fryer has entered Wi-Fi pairing mode, and the lighting will slowly flash every 2 seconds. Long press the Wi-Fi icon  and you will hear 1 beep sound, then the light signal lighting will flash very fast (flash every 0.25 seconds), which means your phone can link this Wi-Fi function now. (Remember to open the Bluetooth in your smartphone). When Wi-Fi is connected, the Wi-Fi lighting  will be illuminated and stop flashing.
4. In the Rohnson app, press "Add device" and an update window will appear on your mobile phone screen to install your device.

## General description

1. Basket
2. Basket handle
3. Transparent window
4. Digital Touch Control Panel
5. Air inlet
6. Air outlet openings
7. Mains cord
8. Frying tray
9. Water tank

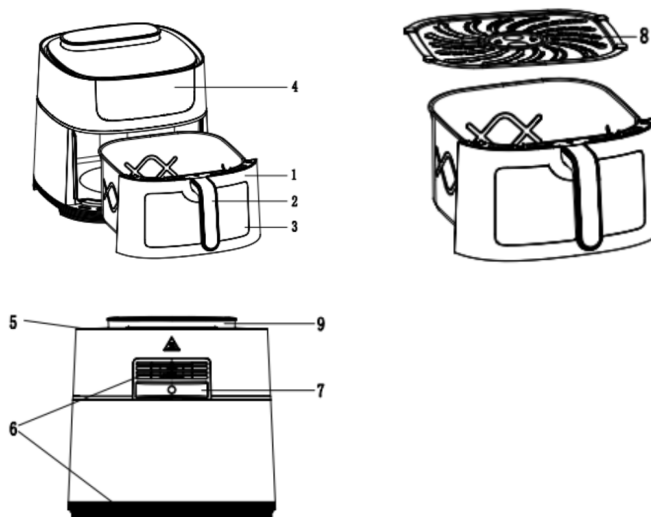

## Attaching the fry basket handle:

The fry basket handle might come disassembled in your appliance's packaging. To attach the fry basket handle:

- Remove the paper label. Pull the fry basket out of the appliance.
- Slide the attachment point on the handle downward until it clicks into place.

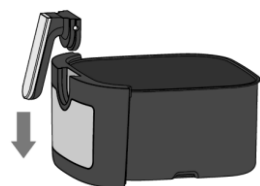

- The fry basket handle should lock into place and should not detach once it is locked into place.

### **Removing the fry basket handle:**

To remove the fry basket handle:

Use a tool, such as a screwdriver, to lift the silicone on the fry basket handle.

Align the tool with the hole and push down, then tilt the tool inward.

Grab the handle with your hand and pull it out. Done.



### **Significance**

Please read this manual carefully before using the appliance as damage may occur under incorrect operations. Pls keep this manual for future reference.

### **Danger**

- Do not immerse the housing in water or rinse under the tap due to the multi-electrical and heating components.
- Do not let liquid enter the appliance to prevent electric shock or short-circuit.
- Keep all ingredients in the basket to prevent any contact from heating elements.
- Do not cover the air inlet and the air outlet when the appliance is working.
- Filling the basket with oil may cause a fire hazard.
- Do not touch the inside of the appliance while it is operating.

### **Warning**

- Check if the voltage indicated on the appliance fits the local power voltage.
- Do not use the appliance if there is any damage on plug, power cord or other parts.
- Do not go to any unauthorized person to replace or fix a damaged power cord.
- Keep the appliance and its power cord out of the reach of children.
- Keep the power cord away from hot surfaces.
- Do not plug the appliance or operate the control panel with wet hands.
- Always make sure that the plug is inserted into the wall socket properly.
- Do not connect appliance to an external timer switch.
- Do not place the appliance on or near combustible materials such as a tablecloth or curtain.
- Do not place the appliance against a wall or against other appliance. Leave at least 10cm free space on the back and sides and 10cm free space above the appliance.
- Do not place anything on top of the appliance.
- Do not use the appliance for any other purpose than described in this manual.
- Do not leave the appliance unattended.
- During hot air frying, hot steam is released through the air outlet openings. Keep

your hands and face at a safe distance from the steam and from the air outlet openings. Also be careful of hot steam and air when you remove the pan from the appliance. Any accessible surfaces may become hot during use.

- Immediately unplug the appliance if you see dark smoke coming out of the appliance. Wait for the smoke emission to stop before you remove the pan from the appliance.

## **Caution**

- Ensure that appliance is placed on a horizontal, even and stable surface.
- This appliance is designed for household use only. It is not suitable to be safely used in environments such as staff kitchens, farms, motels, and other non-residential environments.
- The warranty is invalid if the appliance is used for professional or semi-professional purposes, or it is not used according to instructions. (Never use the appliance when the plug is damaged.)
- The appliance needs approximately 30 minutes to cool down before it is safe to handle or clean.

## **Automatic switch-off**

The appliance has a built-in timer, it will automatically shut down the appliance when count down reaches zero. You can manually switch off the appliance by pressing off button, it will automatically shut down the appliance in 20 seconds.

## **Before first use**

1. Remove all packaging materials and stickers or labels.
2. Clean the basket and rack with hot water, with some washing liquid and a non-abrasive sponge. These parts are safe to be cleaned in dishwasher.
3. Wipe inside and outside of the appliance with a clear cloth. And there is no need to fill the basket with oil and frying fat as the appliance works on hot air.

## **Using the appliance**

- 1 Connect the mains plug into an earthed wall socket.
- 2 Carefully pull the basket out of the air fryer.
- 3 Place the ingredients in the basket.
- 4 Slide the basket into the air fryer.

**Note:** Do not exceed the MAX indication (see section “settings” in this chapter), as it may affect the cooking quality of the food.

**Caution:** Do not touch the basket during and in short-time after use, as it gets very hot. Only hold the basket by the handle.

5. Do not fill the basket with oil or any other liquid.
6. Finger touch Power on/off.
7. Finger touch Menu to choose functions (totally 8 functions).

## Control panel presentation



Notes: 8 functions are provided: Chicken leg, Steak, Fish, Cake, Pizza, Hot dog, Fries, and Dehydrate. You can use choose different cooking food you like.

## Menu presetting:

Menu	Icon Button	Default Temp	Default Time	Shake	Soft cooking (optional)
Default	/	185°C	15min	Shake	Yes
Chicken	/	200°C	23min	Shake	Yes
Steak	/	200°C	12min	Shake	Yes
Fish	/	195°C	10min	Shake	Yes
Bake	/	160°C	30min	/	/
Pizza	/	185°C	8min	/	/
Hotdog	/	185°C	8min	Shake	Yes
Fries	/	200°C	23min	Shake	Yes
Dehydrate	/	65°C	4h	/	/
Temp Range	80°C~200°C (Dehydrate: 30-80°C)	/	/	/	/
Time Range	1min~60min (Dehydrate: 2-24h)	/	/	/	/

After touching menu button, you can choose menu you like. After choosing the function, please finger Start/Pause button  to start cooking.

During the cooking process, if you want to adjust time or temperature, kindly press the

Time/temperature button  first. When the display on screen shows time, then press the +/- button to increase/decrease 1 minute per a press. When the display on screen

shows the temperature, then press +/- button to increase/decrease 5 degree per a press.

Start/Pause button  : During the hot air frying process, the LED lamp will be running, then if press this button, the LED lamp will be blinks. Here, this button acts as pause function. In the pause state, you can change menu to choose other presetting. Then, you press this button again, the air fryer will continue cooking. Here, this button acts as re-start function.

Menu button choose different cooking functions. After you choose the menu, press the start button. When during the cooking period, for example, you want to change chips to cake, then first press the Pause button , then touching cake menu button to switch to different cooking function.

**Note:** When the appliance is under cooking mode, if long press this menu button for 7 seconds, this appliance will be reset and back to the initial mode.

Light button: Touch this button , the inside light will be on; Touch this button again and the light will be off. The light will automatically turn off 20 seconds later.

Shake indicator (**SHAKE**) : The shake indicator will illuminate when the cooking cycle has reached its halfway point. This halfway time gives you the opportunity to shake or flip your food in appliance, which helps ensure even cooking.

**Note:** If you do not remove the basket and shake the food, the shake light on the control panel will remain illuminated.

Some ingredients require to shake halfway during the preparation time (see section 'settings' in this chapter). By this way, pull the basket out of the appliance by the handle and shake it. Then slide the basket back into the air fryer.

8. Machine will have Auto ready bell after cooking. When you hear bell for 5 times, this means the cooking cycle is finished. Pull the basket out of the appliance and place it on the heat-resistant holder.

**Note:** After the time ends, the heating element stops working, but the fan will continue to run about 20 seconds to blow away the hot air as safety. Finally, the timer bell will ring for 5 times as the ending alarm.

9. Check if the ingredients are ready.

**Note:** If the ingredients are not ready yet, simply slide the basket back into the appliance. Press the temperature control knob to adjust Temperature setting and press the Timer control button to adjust time setting. And then press the Start button to run the appliance.

10. To remove ingredients, (e.g. beef, chicken, meat, any ingredients with original oil and will have excess oil from ingredients collected on the bottom of the basket), please use tongs to pick ingredients one by one.

**Note:** Be careful if you want to turn the basket over, the oil collected on the bottom of the basket will leak onto the ingredients.

11. To remove ingredients (e.g. chips, vegetable or ingredients with no excess oil from the ingredients), please turn off the basket, and pour ingredients to tableware.

Tip: To remove large or fragile ingredients, lift the ingredients out of the basket by a pair of tongs.

12. When a batch of ingredients is ready, the fryer is instantly ready for preparing another batch.

## Soft cooking function

Soft cooking function will spray water drop onto the food during cooking, to reserve juicy and keep the food moist. This function is mainly used for cooking seafood, vegetable, chicken, dumplings which may get too dry or even burn under normal air fryer mode.

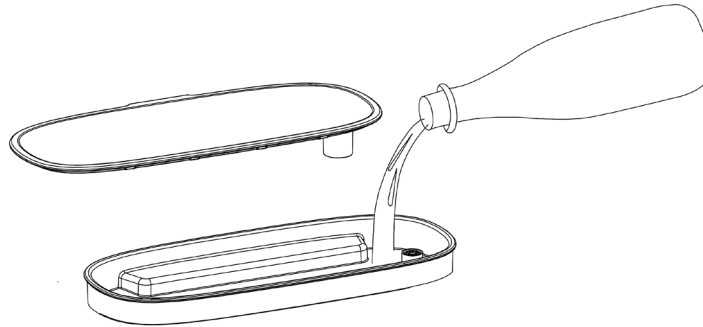

1. Water filling in the water tank: Remove the water tank from the machine, open the lid of the water tank, add enough water into the water tank. Then put back the lid and place the water tank on to the product.

**Note:** Please use pure water for cooking. No tap water.

**Note:** Do not pour water directly onto the top of the product, so as to avoid water entering the inside of the product.

**Note:** Please fill up the water tank before use the soft cooking function.

**Note:** The water tank capacity is **200ml**, please don't fill too much water.

2. Put in the food: Pull out the basket, then put the food inside. Slide the basket back to the product.

**Note:** Please spread the food as much as possible to get a better cooking.

3. Setting the function: Select the wanted cooking recipe or set the temperature/time directly.

Press the button  to active soft cooking function. (The icon will flash when it is active.)

**Note:** There is no soft cooking function for Pizza, Bake or Dehydrate mode.

Press start button  to start the cooking. The water drop will be sprayed onto the food automatically during cooking.

## Settings

This table below will help you to select the basic settings for the ingredients.

**Note:** Keep in mind that these settings are indications. As ingredients differ in origin, size, shape and brand, we cannot guarantee the best setting for your ingredients.

Because the Rapid Air technology reheats the air inside the appliance instantly, pull the basket briefly out of the appliance during hot air frying barely disturbs the process.

	Min-Max (g)	Time (Min)	Temp °C	Shake	Remark
French fries					
Thin frozen fries	300-700	9-16	200	Y	
Thick frozen fries	300-700	11-20	200	Y	
Home-made fries (8X8mm)	300-800	10-16	200	Y	Add 1/2 tbsp of oil
Homemade potato wedges	300-800	18-22	180	Y	Add 1/2 tbsp of oil
Home-made potato cubes	300-750	12-18	180	Y	Add 1/2 tbsp of oil
	250	15-18	180	Y	
Potato gratin	500	15-18	200	Y	
Steak	100-500	8-12	180		
Meat chops	100-500	10-14	180		
Hamburger	100-500	7-14	180		
Sausage roll	100-500	13-15	200		
Drumsticks	100-500	18-22	180		
Chicken breast	100-500	10-15	180		
Snacks					
Spring rolls	100-400	8-10	200	Y	
Frozen chicken nuggets	100-500	6-10	200	Y	
Frozen fish fingers	100-400	6-10	200		
Frozen bread crumbed	100-400	8-10	180		
Stuffed vegetables	100-400	1-10	160		
Cake	300	20-25	160		
Quiche	400	20-22	180		
Muffins	300	15-18	200		
Sweet snacks	400	1-20	160		

## Tips

- Small ingredients usually require a slightly shorter preparation time than larger ingredients.
- A larger amount of ingredients only requires a slightly longer preparation time, a smaller amount of ingredients only requires a slightly shorter preparation time.
- Shaking smaller ingredients halfway during the preparation time optimizes the result and can help prevent unevenly fried ingredients.
- Add some oil to fresh potatoes and fry your ingredients for another few minutes then for a crispy result.
- Do not prepare extremely greasy ingredients such as sausages in the air fryer.
- Snacks can be prepared in an oven can also be prepared in the air fryer.
- The optimal amount for prepare crispy fries is 500 grams.



- Use pre-made dough to get snacks quickly and easily. Pre-made dough also requires a shorter preparation time than home-made dough.
- Place a baking tin or oven dish in the fryer basket if you want to bake a cake or quiche or if you want to fry fragile ingredients or filled ingredients.
- You can also use the air fryer to heat ingredients. To heat ingredients, set the temperature to 150°C for up to 10 minutes.

### Making home-made fries

To make home-made fries, follow the steps below:

1. Peel and slice the potatoes.
2. Wash the potato sticks thoroughly and dry them with kitchen paper.
3. Pour 1/2 tablespoon of olive oil in a bowl, put the sticks on top and mix until the sticks are coated with oil.
4. Remove the sticks from the bowl with your fingers or a kitchen utensil so that excess oil stays behind in the bowl. Put the sticks in the basket.
5. Fry the potato sticks according to the instructions in this chapter.

## **Cleaning**

Clean the appliance after every use.

Do not clean the basket, the rack and the inside of the appliance by metal kitchen utensils or abrasive cleaning materials, as this may damage the non-stick coating of them. Remove the mains plug from the wall socket to make the appliance cool down.

**Note:** Remove the basket to let the fryer cool down more quickly.

Wipe the outside of the appliance with a moist cloth.

Clean the basket and rack with hot water, some washing-up liquid and a non-abrasive sponge. You can remove any remaining dirt by degreasing liquid.

**Note:** The basket and rack are dishwasher-proof.

**Tip:** If dirt is stuck to the rack or the bottom of the basket, fill the basket with hot water with some washing-up liquid. Put the rack in the basket and let them soak for about 10 minutes.

Clean the inside of the appliance with hot water and non-abrasive sponge.

Clean the heating element with a cleaning brush to remove any food residues.

## **Water Tank Cleaning**

After a period of use, the inside of the tank may breed bacteria. Please clean the tank regularly. Just open the lid of the tank and rinse it under the current or clean it with a damp cloth.

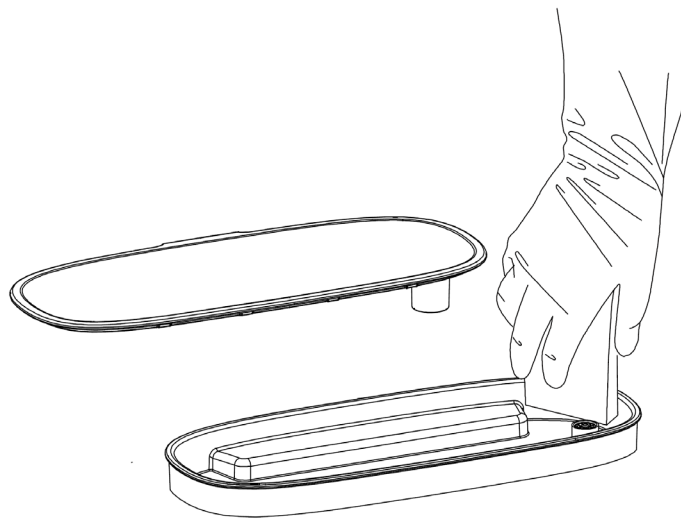

## **Storage**

1. Unplug the appliance and let it cool down thoroughly.
2. Make sure all parts are clean and dry.

## **Login Details**

The device is only compatible with software systems: IOS and Android. The software versions that are accepted are IOS 11.0 and above and Android 5 and above.

**Disclaimer:** Due to the special cases during the use of the application, we expressly state the following:

1. **Not all Android and IOS systems are compatible with the app. We bear no responsibility for any matter as a result of incompatibility.**
2. WPA-PSK / WPA2-PSK encryption is recommended.
3. Due to different network conditions, sometimes one request may time out, therefore it is necessary to do the network configuration again.
4. Due to different network conditions, sometimes the app checking and installation process may time out. In this case, don't worry, follow the installation instructions and try again.

**Caution:** It is necessary to block any other wireless network and make sure that the mobile phone or tablet device is connected to the network you want to set up. Additionally, make sure that your device's Wi-Fi connection is working properly and that it can reconnect to your network automatically.

## **IMPORTANT NOTE**

During the first installation of the device with the local wireless Wi-Fi network of the area, it is recommended that both the Air Fryer device and the mobile phone or tablet you will use are at a distance of less than one (1) meter from the modem-router. After installation you can place the Air Fryer at a distance of up to 50 meters from the

modem-router. This distance can be affected by different conditions in the location of the device and also by the range of the wireless network used.

## NOTE

The Vasiliias SA company bears no responsibility for problems caused by the Internet connection, the Wi-Fi router or other smart devices. Please contact your provider for further assistance.

## Using the Rohnson app

The air fryer can be operated manually with its built-in controls, or you can use a Smartphone to control it. Before you start, make sure the Rohnson Wi-Fi app is downloaded.

## Download and Install the App

As users of Android and IOS devices, search for the app on Google Play or APP Store, respectively, by typing **Rohnson** in the search field.

**Note:** The language of the application (Greek or English) is adjusted according to the language of the phone or tablet device installed on your device.

**Caution: Please make sure your device is connected to a Wi-Fi router. Also, that the Wi-Fi router is already connected to the Internet before proceeding with user registration.**

**Note: Vasiliias S.A. respects the user's personal data and expressly declares that it will not use the user's personal data for any advertising reason or for any other reason, without the user's prior written consent.**

## User Registration



Image 1

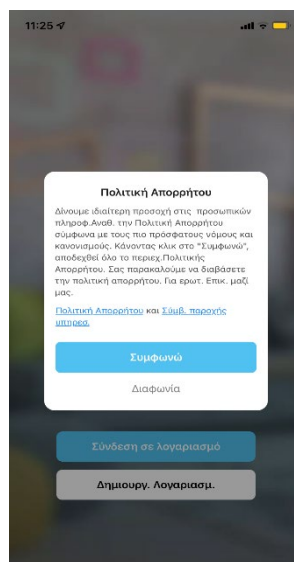

Image 2

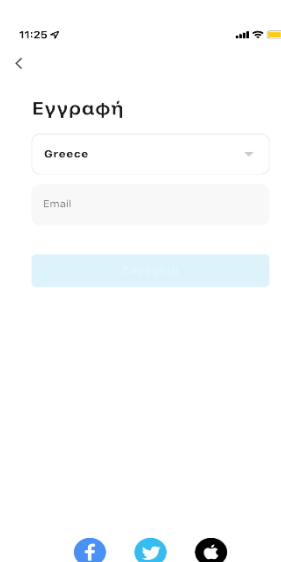
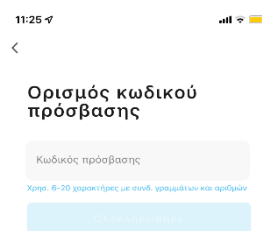

Image 3

Completing the installation process for the Rohnson app and choosing to launch it should go through the process of creating an initial user account. (Image 1)

During the **Registration** process, the user must accept the **Privacy Policy** and then fill in the field with a valid mobile phone number or a valid E-mail address (Image 2 and 3). The application automatically recognizes the country you are in. Otherwise, you can choose the country you want.

- If you choose to top up your mobile phone or an e-mail account, a new message will be sent to your phone or account with a unique code. This code should be filled in the Verification Code field and then enter the code of your choice in the Set Password field (Image 4).
- Select **Done** and the process is completed.



**Image 4**

## **NOTE**

The user is not charged for receiving the messages and neither should he answer for any reason to the number receiving the messages. Vasiliias S.A. is responsible for answering any question that may arise during the operation of the air fryer.

## **NOTE**

The password should contain 6 to 20 letters and numbers.

## **Login with SMS**

You can log in using SMS. Select **Connect with SMS**. The application automatically recognizes the country you are in. Otherwise, you can choose it according to your choice. Choose to top up your mobile phone or online account, then select **Continue**,

a new message will be sent to your phone or online account with a unique code. This code should be filled in the **Verification Code** field.

### **You forgot the Password**

If you have lost your password, please follow the procedure below:

1. Select the **Forgot password** option.
2. The application automatically recognizes the country you are in. Otherwise you can choose it according to your choice.
3. Choose to fill in your mobile phone or the e-mail address (E-mail) that you stated during your initial registration and then choose **Continue**.
4. A new message will be sent to your phone or email with a unique code.

This code should be filled in the **Verification Code** field. Then set your New password in the **Enter password field** and select **Confirm**.

### **Add device and network connection process**

After completing the initial user registration in the application, we continue with the process of adding the air fryer device to the application and connecting it to the local Wi-Fi network.

On the home screen we select either the **Add device** option or the **+** symbol at the top right of our screen (Image 5).

Check **AGAIN** that the network indicator is flashing too fast (twice per second) and select **Indicator is flashing too fast**. Also, through the app you can find instructions on how to set the network indicator to flash very fast (twice a second) by selecting on our screen **Instructions** for the indicator or top right **Features**.

**Caution: Please make sure your device is connected to your local Wi-Fi router. Also, that the Wi-Fi router is already connected to the Internet before proceeding to add the device.**

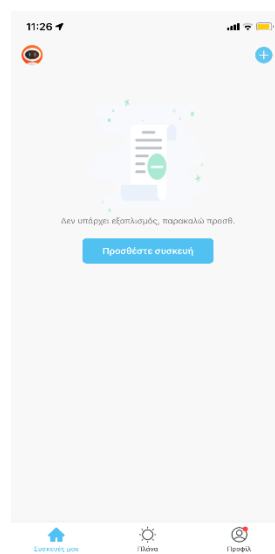

**Image 5**

Then, we enter the Wi-Fi code of the local network in the corresponding field and select **Confirm** (Image 6). In addition, on this screen we are given the possibility, if this has not been done at first, to choose the correct local Wi-Fi network that we want to connect to by selecting **Change network**.

The connection process starts and takes some time until it is 100% complete. The successful addition of the device will be confirmed shortly. On this screen we can either choose to rename the device with the name of our liking or share with the rest of our family the possibility of using the air fryer.

**Note 1:** The multi-member license process is described in a separate section below.

**Note 2:** In the same application, we can add as many devices as we wish to manage, always following the procedure described above.

Then we select **Completed** to proceed with the start-up of the device.

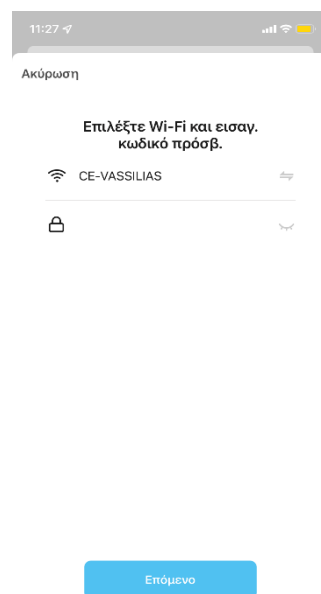

**Image 6**

If the device addition process is not completed successfully, the following screen will appear (Image 7). Please check the following:

- Functionality of local Wi-Fi wireless network.
- Correct selection of the local wireless Wi-Fi network that we want to install.
- Distance of the air fryer device from the router-modem (less than one (1) meter during the first installation).
- Distance of the mobile phone or tablet device from the router-modem and the air fryer device (less than one (1) meter during the first installation).
- Check that the network indicator on the air fryer device flashes very quickly (twice per second).

After completing the above checks, try again by selecting **Try Again** until the process completes successfully.

**Note:** In any case, call Vassilias S.A. to help you if you need any advice during installation.

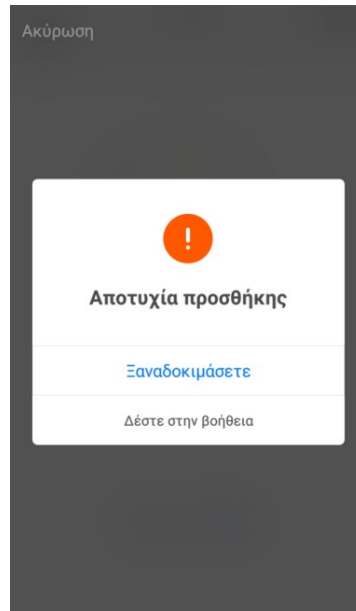

**Image 7**

## **Share devices - Share with your family**

Through the application you can give the possibility to use the air fryer to an additional 3 users - members of your family. The devices of the users you will invite must be compatible. Consult the Important **Precautions section**.

Follow the steps below to complete the process:

- On the initial operating screen of the application, select the symbol .
- On the screen we select Device Sharing.
- Then we select Add Sharing.
- The application automatically recognizes the Region-Country you are in. Otherwise, you can choose it according to your choice.
- Fill in a valid mobile number and a new message will be sent to your registered phone inviting the user to install the app.

## Troubleshooting

Problem	Possible cause	Solution
The AIR FRYER does not work.	The appliance is not plugged in.	Put the mains plug in an earthed wall socket.
	You haven't pressed the start button.	Press the start/power button after you set the temp&time or choose the quick recipe.
The ingredients fried with the AIR FRYER are not done.	The amount of ingredients in the basket is too big.	Put smaller batches of ingredients in the basket. Smaller batches are fried more evenly.
	The set temperature is too low.	Set the temperature to the required Temperature setting.
The ingredients are fried unevenly in the AIR FRYER.	Certain types of ingredients need to be shaken halfway through the preparation time	Ingredients that lie on top of or across each other (e.g. fries) need to be shaken halfway through the preparation time.
Fried snacks are not crispy when they come out of the AIR FRYER.	You used a type of snacks meant to be prepared in a traditional deep fryer.	Use oven snacks or lightly brush some oil onto the snacks for a crisper result.
I can't slide the basket into the appliance properly.	There are too many ingredients in the basket.	Do not fill the basket beyond the MAX indication.
White smoke comes out from the appliance.	You are preparing greasy ingredients.	When you fry greasy ingredients in the AIR fryer, a large amount of oil will leak into the basket. The oil produces white smoke and the basket may heat up more than usual. This does not affect the appliance or the end result.
	The basket still contains grease residues from previous use.	White smoke is caused by grease heating up in the basket. Make sure you clean the basket properly after each use.
Fresh fries are fried unevenly in the AIR FRYER.	You did not use the right potato type.	Use fresh potatoes and make sure that they stay firm during frying.
	You did not rinse the potato sticks properly before you fried them.	Rinse the potato sticks properly to remove starch from the outside of the sticks.
Fresh fries are not crispy when they come out of the AIR FRYER.	The crispiness of the fries depends on the amount of oil and water in the fries.	Make sure you dry the potato sticks properly before you add the oil.
		Cut the potato sticks smaller for a crispier result.
		Add slightly more oil for a crisper result.



## **TECHNICAL SPECIFICATIONS**

### **Radio equipment**

The frequency bands in which the radio equipment operates are 2.4 GHz and the maximum broadcast power is 20dBm.

**Frequency Bands: WIFI: 2.4 G Hz**  
**Maximum broadcast power: 20 dBm**

### **EN**

#### **SIMPLIFIED EU DECLARATION OF CONFORMITY**

Hereby, Ningbo Careline Electric Appliance Co., Ltd declares that the radio equipment type R-2858 is in compliance with Directive 2014/53/EU. The full text of the EU declaration of conformity is available at the following internet address: [www.vassilias.gr](http://www.vassilias.gr)

### **GR**

#### **ΑΠΛΟΥΣΤΕΥΜΕΝΗ ΔΗΛΩΣΗ ΣΥΜΜΟΡΦΩΣΗΣ ΕΕ**

Με την παρούσα ο/η Ningbo Careline Electric Appliance Co., Ltd δηλώνει ότι ο ραδιοεξοπλισμός του R-2858 πληροί την οδηγία 2014/53/ΕΕ. Το πλήρες κείμενο της δήλωσης συμμόρφωσης ΕΕ διατίθεται στην ακόλουθη ιστοσελίδα στο διαδίκτυο: [www.vassilias.gr](http://www.vassilias.gr)

### **BG**

#### **КРАТКА ДЕКЛАРАЦИЯ ЗА СЪОТВЕТСТВИЕ**

С настоящото, Ningbo Careline Electric Appliance Co., Ltd декларира, че радиосъоръжението тип R-2858 е в съответствие с Директива 2014/53 / ЕС. Пълният текст на ЕС декларацията за съответствие е достъпен на следния интернет адрес: [www.vassilias.bg](http://www.vassilias.bg)

### **RO**

#### **DECLARATIE DE CONFORMITATE EU SIMPLIFICATA**

Ningbo Careline Electric Appliance Co., Ltd declara ca echipamentele radio tip R-2858 sunt conforme cu directiva 2014/53/EU. Textul complet al declaratiei de conformitate este disponibil la urmatoarea adresa de internet: <http://vassilias.ro>

### **CZ**

#### **ZJEDNODUŠENÉ EU PROHLÁŠENÍ O SHODĚ**

Ningbo Careline Electric Appliance Co., Ltd tímto prohlašuje, že rádiové zařízení typu R-2858 je v souladu se směrnicí 2014/53/EU. Úplné znění EU prohlášení o shodě je k dispozici na následující internetové adrese: [www.rohnson.cz](http://www.rohnson.cz)

### **SK**

#### **ZJEDNODUŠENÉ EÚ VYHLÁSENIE O ZHODE**

Ningbo Careline Electric Appliance Co., Ltd týmto vyhlasuje, že rádiové zariadenie typu R-2858 je v súlade so smernicou 2014/53/EU. Úplné znenie EÚ vyhlásenia o zhode je k dispozícii na nasledujúcej internetovej adrese: [www.rohnson.cz](http://www.rohnson.cz)



**IMPORTANT INFORMATION FOR CORRECT DISPOSAL OF THE PRODUCT IN ACCORDANCE WITH EC DIRECTIVE 2012/19/EU.**

At the end of its working life, the product must not be disposed of as urban waste. It must be taken to a special local authority differentiated waste collection center or to a dealer providing this service. Disposing of a household appliance separately avoids possible negative consequences for the environment and health, deriving from inappropriate disposal and enables the constituent materials to be recovered to obtain significant savings in energy and resources. As a reminder of the need to dispose of household appliances separately, the product is marked with a crossed-out wheeled dustbin.